

PRODUCT DATA SHEET

Spark Series Server Floor Cabinets

Nitrotel Spark Series offer a select line of cabinet solutions that support and protect network devices, rack-mount servers and other applications in telecommunication equipment rooms, data centers and enterprise cabling applications, while providing an optimized space utilization.

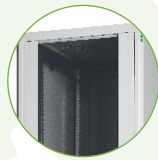
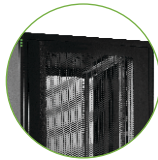

KEY FEATURES AND BENEFITS

- Wide range of cabinets designs and industry-standard sizes available for specific thermal applications.
- Two configurations support front-to-rear airflow or noise reduction.
- Innovative vertical split side panels provide superior access to network devices and cabling.
- Fully compatible with 19" rack-mount equipment.
- Exclusive Flat Pack maximizes space utilization for transportation and storage.

Ordering Information

NTSCXXUXX

Depth (mm): 8 (800), 1 (1000), 12 (1200)
 Width (mm): 6 (600), 8 (800)
 U: 26, 32, 36, 42, 45, 48



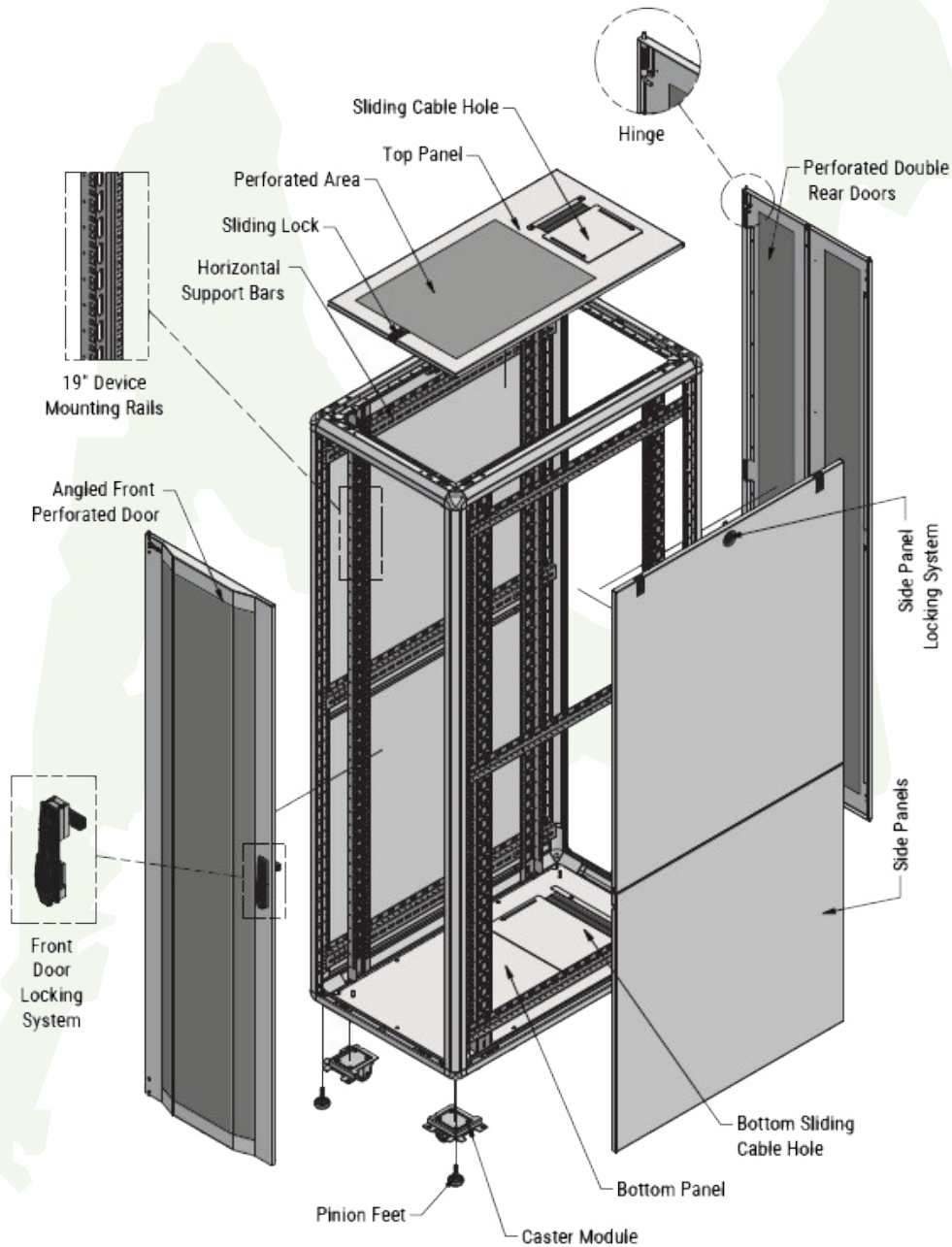

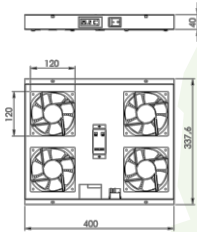

Quick-change fan trays that can be accessed without removing the cabling or the device from the rack

Spark serie's roof panel has been designed for ventilation module which can be detached by removing 4 pcs screws from the top in case of maintenance or replacement needs.

Standards: ISO 9001, CE (89/336/EEC EMC, 73/23/EEC LVD 2006/95/EC), RoHS", Noise 46db , Air FlowM3/Hr 138/162 CFM 82/95.

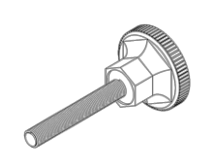
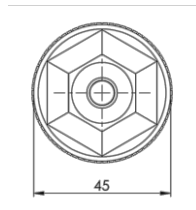
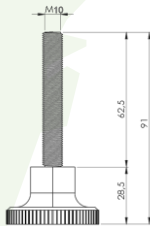
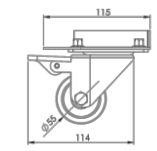
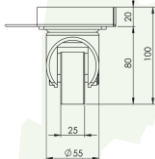
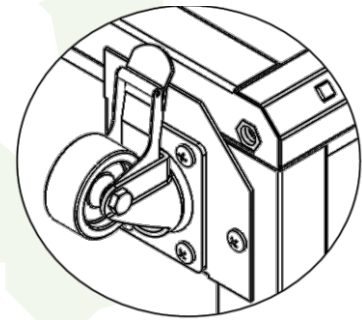
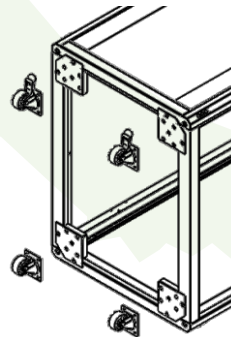
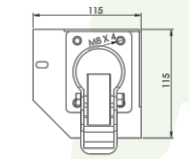
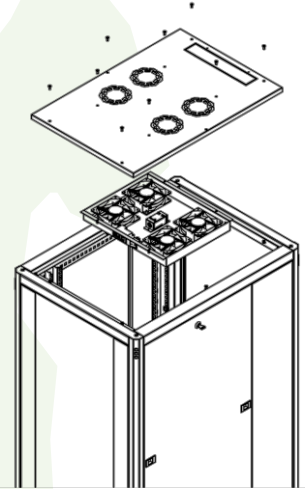

CASTER SET & LEVELLING FEET		
ITEM	DESCRIPTION	INCLUDED IN:
NTCFB30	Spark cabinet castor set of 2 pcs. lockable and rotatable	Server cabinets
NTCF30	Spark cabinet castor set of 2 pcs. rotatable	Server cabinets
NTLFM10	Levelling feet for cabinets (M10)	Server & Network cabinets

Vertical cable management panel

Vertical cable management panel is designed for higher density cabling and connectivity system applications and also offers ease, density, availability, affordability and scalability together.

- Compatible with only width: 800mm rack cabinets (included)
- The vertical cable management panels are adjustable throughout the entire depth of the cabinet with mounting rails.
- Openings between fingers align with each U on the mounting rear
- Hinged cover included with managers, cover snaps closed to secure cables.
- Material: Steel panels, plastic guides and latches.
- Finish: Black or Grey; latches are black.
- Plastic finger type cable managers available upon request.

This well-engineered cable management system offers you a high level of versatility and flexibility for routing and organizing high density cable bundles, KVM and power cables.

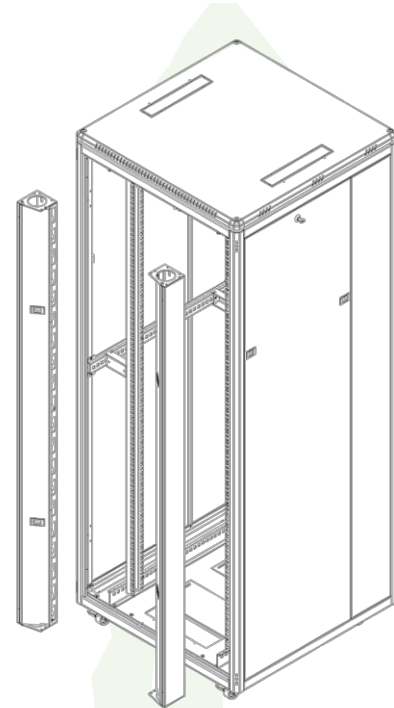

Harmonization system codes—HS code

- 8538.10.00.00.00 : Rack cabinet without accessories
- 85.37.10.99.00.19 : Rack cabinet with accessories

Type of shipping

- Assemble/ Flat-pack

Load carrying capacity

- 1360kg / 3000lbs

Surface treatment

- On flat metal surfaces, there must be 85±5 micron paint thickness and must be tested according to IEC 60068-2-1, IEC 60068-2-2, IEC 60068-2-30, IEC 60068-2-42, IEC 60068-2-43, IEC 60068-2-49, IEC 60068-2-11

Standard color

- Ral: 7035 Light gray/ Ral:9005 Black

Shipment configuration

- Front door with glass or perforations 1 set
- Rear door 1ea
- Side panel 4 pcs (D: 800, 1000 & 1200mm)
- Bottom extension parts 2 pcs
- Upper extension parts 2pcs
- Welded metal frame 2pcs
- C-type rails 2pcs
- 19inch Mounting rail 4pcs
- Bottom plate 1ea
- Roof panel 1ea
- Grounding wire set 1ea
- Screw set 1set
- Swing handle lock 1ea
- Leveling feet 1set - 4pcs
- Casters 1set - 4pcs (server cabinets only)

Packaging

- Wooden pallet 1 ea (ISPM heat treated application)
- Stretch wrapping
- Cardboard
- Plastic strip
- Product label